

### Your Ordering Data:

**GRM2TH-6-45SDS-00-M01-OPEN**

### Order From Your Local Distributor:

OI Technologies - FR  
35 Rue Pierre Carlier  
Montigny-Les-Cormeilles, 95370  
France  
**PHONE:** +33(171)681724  
**FAX:** +33(972)517077  
**EMAIL:** [info@oi-technologies.fr](mailto:info@oi-technologies.fr)  
**WEB SITE:** <http://https://www.oi-technologies.fr>

---

**Contact your local distributor for more information and other automation solutions from PHD.**

---

### **Series GRM Pneumatic Clamp**

Series GRM size 2 clamp is designed specifically for handling sheet metal in stamping/fabricating press applications. A compact size makes the Series GRM size 2 clamp ideal for applications in confined work areas.

**Advantages:** Simple design, long life, high clamp force, six modular designed jaw tips are available.

### **Benefits**

- Ideal for sheet metal handling. Series GRM size 2 clamp is available in 3 sizes, 13 jaw styles, and numerous jaw openings to fit a wide range of clamping applications. Featuring a simple design, long life and high clamp force, this clamp is fully field repairable in a matter of minutes using only metric hex wrenches.
- Compact envelope size and high clamp force. Series GRM size 2 clamp ( design 2 and 6 ) generate up to 225 lb [1,000 N] of clamp force.
- Six modular designed jaw tips are offered for maximum clamping performance in a variety of applications. Additional mounting, jaw, switch and tip options are available.
- Series GRM size 2 clamp ( design 2 and 6 ) jaws lock in the closed position ensuring part retention if air pressure is lost. Wide and deep throates accomodate difficult clamping applications.
- Available with fixed or spherical mounting brackets for side or rear mounting. Two adjustable hardened steel impact plates eliminate damage from panel impact.



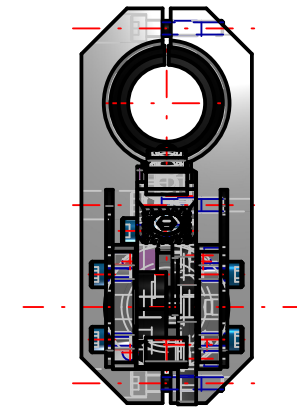
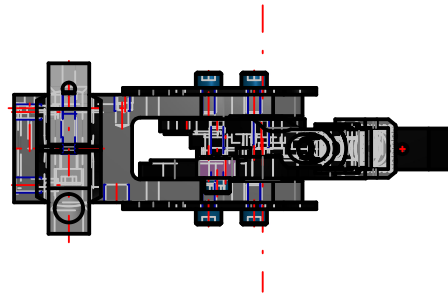
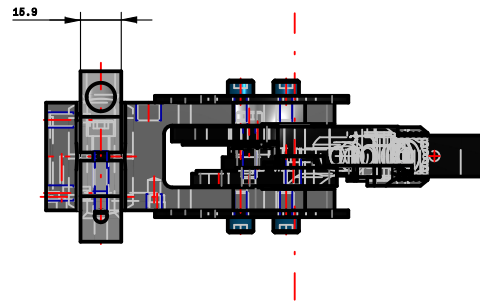
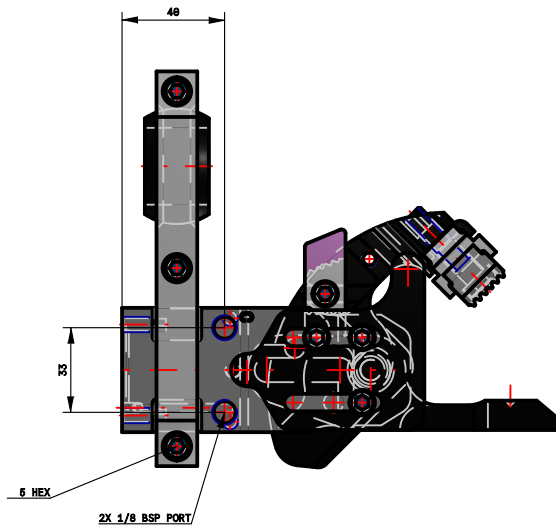
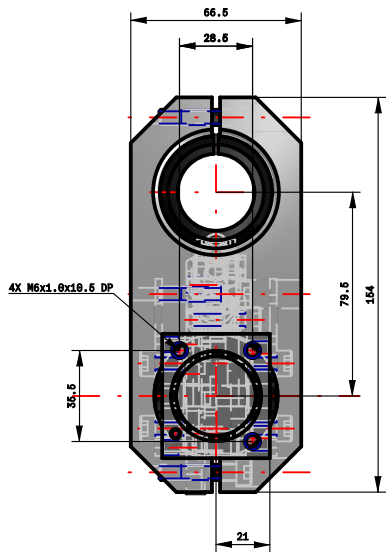

**GRM2TH-6-45SDS-00-M01-OPEN**

PHD, Inc.  
 P.O. Box 9070 • Fort Wayne, IN 46899  
 Tel. (260) 747-6151 • Fax (260) 747-6754  
 www.phdinc.com • phdinfo@phdinc.com